

Combining Logics in Simple Type Theory (and an Application in Ontology Reasoning)

Christoph Benz Müller

Articulate Software, Angwin, CA, USA

SRI, Menlo Park, July 1, 2010

Research funded by
DFG grant BE 2501/6-1



slides available at:

http://www.ags.uni-sb.de/~chris/papers/2010_SRI.pdf



synonyms in this talk
Church's Simple Type Theory
Classical Higher Order Logic (HOL)

- ▶ simple types $\alpha, \beta ::= \iota | o | \alpha \rightarrow \beta$ (opt. further base types)
- ▶ HOL defined by

$$\begin{aligned}
 s, t \quad ::= \quad & p_\alpha \mid X_\alpha \\
 & \mid (\lambda X_\alpha. s_\beta)_{\alpha \rightarrow \beta} \mid (s_{\alpha \rightarrow \beta} t_\alpha)_\beta \\
 & \mid (\neg_{o \rightarrow o} s_o)_o \mid (s_o \vee_{o \rightarrow o \rightarrow o} t_o)_o \mid (\forall X_\alpha. t_o)_o \\
 & \mid (s_\alpha =_{\alpha \rightarrow \alpha \rightarrow o} t_\alpha)_o
 \end{aligned}$$

- ▶ HOL is well understood
 - Origin (Church, J.Symb.Log., 1940)
 - Henkin semantics (Henkin, J.Symb.Log., 1950)
 - (Andrews, J.Symb.Log., 1972)
 - Extens./Intens. (BenzmüllerEtAl., J.Symb.Log., 2004)
 - (Muskens, J.Symb.Log., 2007)

- ▶ simple types $\alpha, \beta ::= \iota | o | \alpha \rightarrow \beta$ (opt. further base types)
- ▶ HOL defined by

$$\begin{aligned}
 s, t \quad ::= & \quad p_\alpha \mid X_\alpha \\
 & \mid (\lambda X_{\alpha \bullet} s_\beta)_{\alpha \rightarrow \beta} \mid (s_{\alpha \rightarrow \beta} t_\alpha)_\beta \\
 & \mid (\neg_{o \rightarrow o} s_o)_o \mid (s_o \vee_{o \rightarrow o \rightarrow o} t_o)_o \mid (\prod_{(\alpha \rightarrow o) \rightarrow o} (\lambda X_{\alpha \bullet} t_o))_o \\
 & \mid (s_\alpha =_{\alpha \rightarrow \alpha \rightarrow o} t_\alpha)_o
 \end{aligned}$$

- ▶ HOL is well understood
 - Origin (Church, J.Symb.Log., 1940)
 - Henkin semantics (Henkin, J.Symb.Log., 1950)
 - (Andrews, J.Symb.Log., 1972)
 - Extens./Intens. (BenzmüllerEtAl., J.Symb.Log., 2004)
 - (Muskens, J.Symb.Log., 2007)

- ▶ simple types $\alpha, \beta ::= \iota | o | \alpha \rightarrow \beta$ (opt. further base types)
- ▶ HOL defined by

$$\begin{aligned}
 s, t \quad ::= \quad & p_\alpha \mid X_\alpha \\
 & \mid (\lambda X_\alpha. s_\beta)_{\alpha \rightarrow \beta} \mid (s_{\alpha \rightarrow \beta} t_\alpha)_\beta \\
 & \mid (\neg_{o \rightarrow o} s_o)_o \mid (s_o \vee_{o \rightarrow o \rightarrow o} t_o)_o \mid (\prod_{(\alpha \rightarrow o) \rightarrow o} s_{\alpha \rightarrow o})_o \\
 & \mid (s_\alpha =_{\alpha \rightarrow \alpha \rightarrow o} t_\alpha)_o
 \end{aligned}$$

- ▶ HOL is well understood
 - Origin (Church, J.Symb.Log., 1940)
 - Henkin semantics (Henkin, J.Symb.Log., 1950)
 - (Andrews, J.Symb.Log., 1972)
 - Extens./Intens. (BenzmüllerEtAl., J.Symb.Log., 2004)
 - (Muskens, J.Symb.Log., 2007)

- ▶ simple types $\alpha, \beta ::= \iota | o | \alpha \rightarrow \beta$ (opt. further base types)
- ▶ HOL defined by

$$\begin{aligned}
 s, t \quad ::= & \quad p_\alpha \mid X_\alpha \\
 & \mid (\lambda X_\alpha. s_\beta)_{\alpha \rightarrow \beta} \mid (s_{\alpha \rightarrow \beta} t_\alpha)_\beta \\
 & \mid (\neg_{o \rightarrow o} s_o)_o \mid (s_o \vee_{o \rightarrow o \rightarrow o} t_o)_o \mid (\prod_{(\alpha \rightarrow o) \rightarrow o} s_{\alpha \rightarrow o})_o \\
 & \mid (s_\alpha =_{\alpha \rightarrow \alpha \rightarrow o} t_\alpha)_o
 \end{aligned}$$

- ▶ HOL is well understood
 - Origin (Church, J.Symb.Log., 1940)
 - Henkin semantics (Henkin, J.Symb.Log., 1950)
 - (Andrews, J.Symb.Log., 1972)
 - Extens./Intens. (BenzmüllerEtAl., J.Symb.Log., 2004)
 - (Muskens, J.Symb.Log., 2007)

- ▶ simple types $\alpha, \beta ::= \iota | o | \alpha \rightarrow \beta$ (opt. further base types)
- ▶ HOL defined by

$$\begin{aligned}
 s, t \quad ::= & \quad p_\alpha \mid X_\alpha \\
 & \mid (\lambda X_\alpha. s_\beta)_{\alpha \rightarrow \beta} \mid (s_{\alpha \rightarrow \beta} t_\alpha)_\beta \\
 & \mid (\neg_{o \rightarrow o} s_o)_o \mid (s_o \vee_{o \rightarrow o \rightarrow o} t_o)_o \mid (\prod_{(\alpha \rightarrow o) \rightarrow o} s_{\alpha \rightarrow o})_o \\
 & \mid (s_\alpha =_{\alpha \rightarrow \alpha \rightarrow o} t_\alpha)_o
 \end{aligned}$$

- ▶ HOL is well understood
 - Origin (Church, J.Symb.Log., 1940)
 - Henkin semantics (Henkin, J.Symb.Log., 1950)
 - (Andrews, J.Symb.Log., 1972)
 - Extens./Intens. (BenzmüllerEtAl., J.Symb.Log., 2004)
 - (Muskens, J.Symb.Log., 2007)

Opinions about HOL:

- ▶ HOL is expressive

but ...

- ▶ HOL can **not** be effectively automated
- ▶ HOL is a classical logic and **not** easily compatible with
 - ▶ modal logics
 - ▶ intuitionistic logic
 - ▶ ...
- ▶ HOL can **not** fruitfully serve as a basis for combining logics

- ▶ HOL is expressive and we exploit this here

but ...

- ▶ HOL can ~~not~~ be effectively automated (at least partly)
- ▶ HOL is a classical logic and ~~not~~ easily compatible with
 - ▶ (normal) modal logics
 - ▶ intuitionistic logic
 - ▶ ...
- ▶ HOL can ~~not~~ fruitfully serve as a basis for combining logics

... I will give theoretical and **practical evidence**



Quantified Multimodal Logics (QML)
as HOL Fragments
(jww Larry Paulson)

Quantified Multimodal Logics (QML)

- ▶ QML defined by

$$\begin{aligned} s, t &::= P \mid (k X^1 \dots X^n) \\ &\mid \neg s \mid s \vee t \\ &\mid \Box_r s \\ &\mid \forall^i X. s \mid \forall^P P. s \end{aligned}$$

- ▶ Kripke style semantics

- ▶ three notions of (QS5) models: (Fitting, J.Symb.Log., 2005)

QS5 π^-

QS5 π

QS5 π^+

(BenzmüllerPaulson, Techn.Report, 2009)

Quantified Multimodal Logics (QML)

- ▶ QML defined by

$$\begin{aligned} s, t &::= P \mid (k X^1 \dots X^n) \\ &\mid \neg s \mid s \vee t \\ &\mid \Box_r s \\ &\mid \forall^i X. s \mid \forall^P P. s \end{aligned}$$

- ▶ Kripke style semantics

- ▶ three notions of (QS5) models: (Fitting, J.Symb.Log., 2005)

$$\mathbf{QS5}\pi^- \longrightarrow \mathbf{QK}\pi^-$$

$$\mathbf{QS5}\pi \longrightarrow \mathbf{QK}\pi \quad (\text{correspondence to Henkin models})$$

$$\mathbf{QS5}\pi^+ \longrightarrow \mathbf{QK}\pi^+$$

(BenzmüllerPaulson, Techn.Report, 2009)

(Normal) QML as Fragment of HOL

— related, but significantly extending (Ohlbach, 1988/93) —

Straightforward encoding

- ▶ base type ι : non-empty set of possible worlds
- ▶ base type μ : non-empty set of individuals

QML formulas \longrightarrow HOL terms of type $\iota \rightarrow o$

QML operators as abbreviations for specific HOL terms

$$\neg = \lambda\phi. \lambda W \iota. \neg\phi W$$

$$\vee = \lambda\phi. \lambda\psi. \lambda W. \phi W \vee \psi W$$

$$\square = \lambda R. \lambda\phi. \lambda W. \forall V. \neg R W V \vee \phi V$$

$$(\forall^i) \quad \Pi^\mu = \lambda\tau. \lambda W. \forall X. (\tau X) W \quad (\text{quantif. over individuals})$$

$$(\forall^P) \quad \Pi^{\iota \rightarrow o} = \lambda\tau. \lambda W. \forall P. (\tau P) W \quad (\text{quantif. over propositions})$$

(Normal) QML as Fragment of HOL

— related, but significantly extending (Ohlbach, 1988/93) —

Straightforward encoding

- ▶ base type ι : non-empty set of possible worlds
- ▶ base type μ : non-empty set of individuals

QML formulas \longrightarrow HOL terms of type $\iota \rightarrow o$

QML operators as abbreviations for specific HOL terms

$$\neg = \lambda\phi_{\iota \rightarrow o} \cdot \lambda W_{\iota} \cdot \neg \phi W$$

$$\vee = \lambda\phi_{\iota \rightarrow o} \cdot \lambda\psi_{\iota \rightarrow o} \cdot \lambda W_{\iota} \cdot \phi W \vee \psi W$$

$$\square = \lambda R_{\iota \rightarrow \iota \rightarrow o} \cdot \lambda\phi_{\iota \rightarrow o} \cdot \lambda W_{\iota} \cdot \forall V_{\iota} \cdot \neg R W V \vee \phi V$$

$$(\forall^i) \quad \Pi^{\mu} = \lambda\tau_{\mu \rightarrow (\iota \rightarrow o)} \cdot \lambda W_{\iota} \cdot \forall X_{\mu} \cdot (\tau X) W$$

$$(\forall^P) \quad \Pi^{\iota \rightarrow o} = \lambda\tau_{(\iota \rightarrow o) \rightarrow (\iota \rightarrow o)} \cdot \lambda W_{\iota} \cdot \forall P_{\iota \rightarrow o} \cdot (\tau P) W$$

Encoding of validity

$$\text{valid} = \lambda\phi_{\iota \rightarrow o}. \forall W_{\iota}. \phi W$$

Example: In all r -accessible worlds exists truth

Formulate problem in HOL using original QML syntax

$\text{valid } \Box_r \exists^P P_{l \rightarrow o} P$

then automatically rewrite abbreviations

$\Box_r \xrightarrow{\text{rewrite}} \dots$
 $\exists^P \xrightarrow{\text{rewrite}} \dots$
 $\text{valid} \xrightarrow{\text{rewrite}} \dots$
 $\xrightarrow{\beta\eta\downarrow} \forall W_{l^*} \forall Y_{l^*} \neg r W Y \vee (\neg \forall P_{l \rightarrow o} \neg (P Y))$

and prove automatically (LEO-II, IsabelleP, TPS, Satallax, ...
here the provers need to generate witness term $P = \lambda Y_{l^*} \top$)

Example: In all r -accessible worlds exists truth

Formulate problem in HOL using original QML syntax

$$\text{valid } \Box_r \exists^P P_{l \rightarrow o} P$$

then automatically rewrite abbreviations

$$\begin{array}{l} \Box_r \xrightarrow{\text{rewrite}} \dots \\ \exists^P \xrightarrow{\text{rewrite}} \dots \\ \text{valid} \xrightarrow{\text{rewrite}} \dots \\ \xrightarrow{\beta\eta\downarrow} \forall W_{l^*} \forall Y_{l^*} \neg r W Y \vee (\neg \forall P_{l \rightarrow o} \neg (P Y)) \end{array}$$

and prove automatically (LEO-II, IsabelleP, TPS, Satallax, ...
here the provers need to generate witness term $P = \lambda Y_{l^*} \top$)

Example: In all r -accessible worlds exists truth

Formulate problem in HOL using original QML syntax

$$\text{valid } \Box_r \exists^P P_{l \rightarrow o} P$$

then automatically rewrite abbreviations

$$\begin{array}{l} \Box_r \xrightarrow{\text{rewrite}} \dots \\ \exists^P \xrightarrow{\text{rewrite}} \dots \\ \text{valid} \xrightarrow{\text{rewrite}} \dots \\ \xrightarrow{\beta\eta\downarrow} \forall W_{l^*} \forall Y_{l^*} \neg r W Y \vee (\neg \forall P_{l \rightarrow o} \neg (P Y)) \end{array}$$

and prove automatically (LEO-II, IsabelleP, TPS, Satallax, ...
here the provers need to generate witness term $P = \lambda Y_{l^*} \top$)

Soundness and Completeness Theorem:

$\models_{\mathbf{QK}\pi}^{QML} s$ if and only if $\models_{Henkin}^{HOL} \text{valid } s_{\iota \rightarrow o}$

(BenzmüllerPaulson, Techn.Report, 2009)

Soundness and Completeness Theorem for Propositional Multimodal Logic

(BenzmüllerPaulson, Log.J.IGPL, 2010)

Further interesting Fragments of HOL

- ▶ Intuitionistic Logic
(exploiting Gödel's translation to S4)
(BenzmüllerPaulson, Log.J.IGPL, 2010)
- ▶ Access Control Logics
(exploiting a translation by Garg and Abadi)
(Benzmüller, IFIP SEC, 2009)
- ▶ Region Connection Calculus — later in this talk
- ▶ ...



Reasoning about Combinations of Logics

Reasoning about Combinations of Logics: Correspondence

Correspondences between properties of accessibility relations like

$$\text{symmetric} = \lambda R. \forall S, T. R S T \Rightarrow R T S$$

$$\text{serial} = \lambda R. \forall S. \exists T. R S T$$

and corresponding axioms

$$\forall R. \text{symmetric } R \stackrel{0,0s}{\Leftarrow} \Rightarrow \text{valid } \forall^P \phi. \phi \supset \Box_R \Diamond_R \phi \quad (B)$$

$$\forall R. \text{serial } R \stackrel{0,0s}{\Leftarrow} \Rightarrow \text{valid } \forall^P \phi. \Box_R \phi \supset \Diamond_R \phi \quad (D)$$

Such proofs — including axioms D, M, 4, B, 5 — can be automated with LEO-II in no-time!

Reasoning about Combinations of Logics: Correspondence

Correspondences between properties of accessibility relations like

$$\text{symmetric} = \lambda R. \forall S, T. R S T \Rightarrow R T S$$

$$\text{serial} = \lambda R. \forall S. \exists T. R S T$$

and corresponding axioms

$$\forall R. \text{symmetric } R \stackrel{0,0s}{\Leftarrow} \stackrel{0,0s}{\Rightarrow} \text{valid } \forall^P \phi. \phi \supset \Box_R \Diamond_R \phi \quad (B)$$

$$\forall R. \text{serial } R \stackrel{0,0s}{\Leftarrow} \stackrel{0,0s}{\Rightarrow} \text{valid } \forall^P \phi. \Box_R \phi \supset \Diamond_R \phi \quad (D)$$

Such proofs — including axioms D, M, 4, B, 5 — can be automated with LEO-II in no-time!

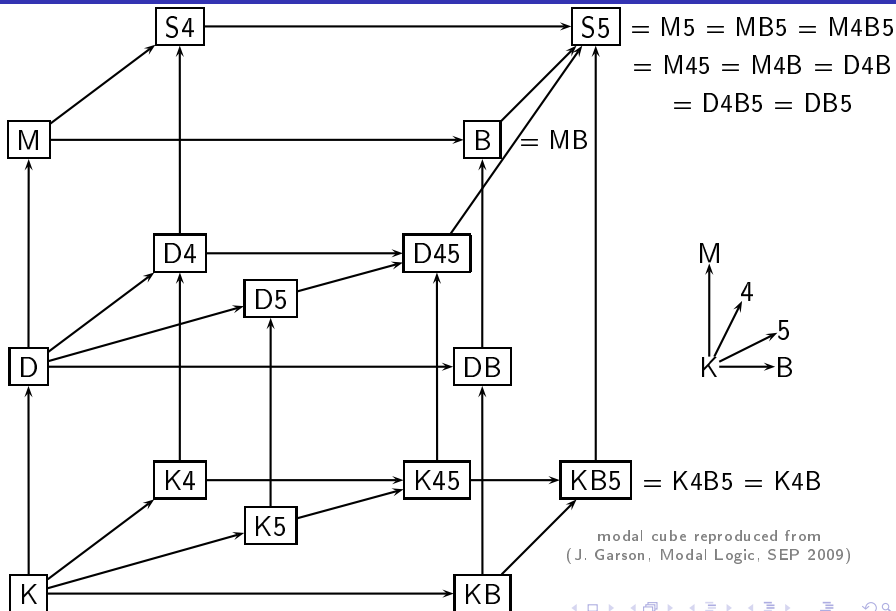

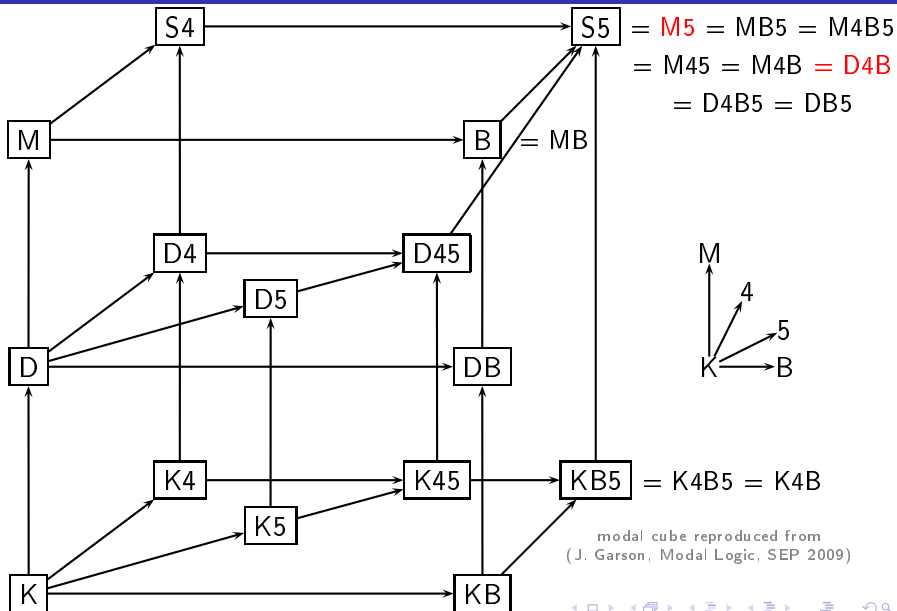

$\forall R.$

$$\wedge \left. \begin{array}{l} \text{valid } \forall^P \phi. \Box_R \phi \supset \phi \\ \text{valid } \forall^P \phi. \Diamond_R \phi \supset \Box_R \Diamond_R \phi \end{array} \right\} M5$$

 \Leftrightarrow

$$\wedge \left. \begin{array}{l} \text{valid } \forall^P \phi. \Box_R \phi \supset \Diamond_R \phi \\ \text{valid } \forall^P \phi. \Box_R \phi \supset \Box_R \Box_R \phi \\ \text{valid } \forall^P \phi. \phi \supset \Box_R \Diamond_R \phi \end{array} \right\} D4B$$

$\forall R.$

$$\wedge \left. \begin{array}{l} \text{valid } \forall^P \phi. \Box_R \phi \supset \phi \\ \text{valid } \forall^P \phi. \Diamond_R \phi \supset \Box_R \Diamond_R \phi \end{array} \right\} M5$$

 \Leftrightarrow

$$\wedge \left. \begin{array}{l} \text{serial } R \\ \text{valid } \forall^P \phi. \Box_R \phi \supset \Box_R \Box_R \phi \\ \text{symmetric } R \end{array} \right\} D4B$$

$\forall R.$ \wedge reflexive R
 \wedge euclidean R } M5 \Leftrightarrow \wedge serial R
 \wedge transitive R
 \wedge symmetric R } D4B

$\forall R.$

\wedge reflexive R
 \wedge euclidean R

} M5

0.1s
 \Leftrightarrow

\wedge serial R
 \wedge transitive R
 \wedge symmetric R

} D4B

Proof with LEO-II in 0.1s

Reasoning about Combinations of Logics: Cube Verification

$S5 = M5 \Leftrightarrow MB5$
 $\Leftrightarrow M4B5$
 $\Leftrightarrow M45$
 $\Leftrightarrow M4B$
 $\Leftrightarrow D4B$
 $\Leftrightarrow D4B5$
 $\Leftrightarrow DB5$

$KB5 \Leftrightarrow K4B5$
 $\Leftrightarrow K4B$

$M5 \Rightarrow D45$
 $D45 \Rightarrow M5$

Reasoning about Combinations of Logics: Cube Verification

S5 = M5 $\overset{0.1s}{\Leftrightarrow}$ MB5
 $\overset{0.2s}{\Leftrightarrow}$ M4B5
 $\overset{0.1s}{\Leftrightarrow}$ M45
 $\overset{0.1s}{\Leftrightarrow}$ M4B
 $\overset{0.1s}{\Leftrightarrow}$ D4B
 $\overset{0.2s}{\Leftrightarrow}$ D4B5
 $\overset{0.1s}{\Leftrightarrow}$ DB5

KB5 $\overset{0.2s}{\Leftrightarrow}$ K4B5
 $\overset{0.1s}{\Leftrightarrow}$ K4B

M5 $\overset{0.1s}{\Rightarrow}$ D45
D45 $\overset{???}{\Rightarrow}$ M5

Proofs with LEO-II < 0.2s

Reasoning about Combinations of Logics: Cube Verification

$S5 = M5 \Leftrightarrow MB5$
 $\Leftrightarrow M4B5$
 $\Leftrightarrow M45$
 $\Leftrightarrow M4B$
 $\Leftrightarrow D4B$
 $\Leftrightarrow D4B5$
 $\Leftrightarrow DB5$

$KB5 \Leftrightarrow K4B5$
 $\Leftrightarrow K4B$

$M5 \Rightarrow D45$
 $D45 \not\Rightarrow M5$

Countermodel 34.4s (IsabelleN)

Reasoning about Combinations of Logics: Cube Verification

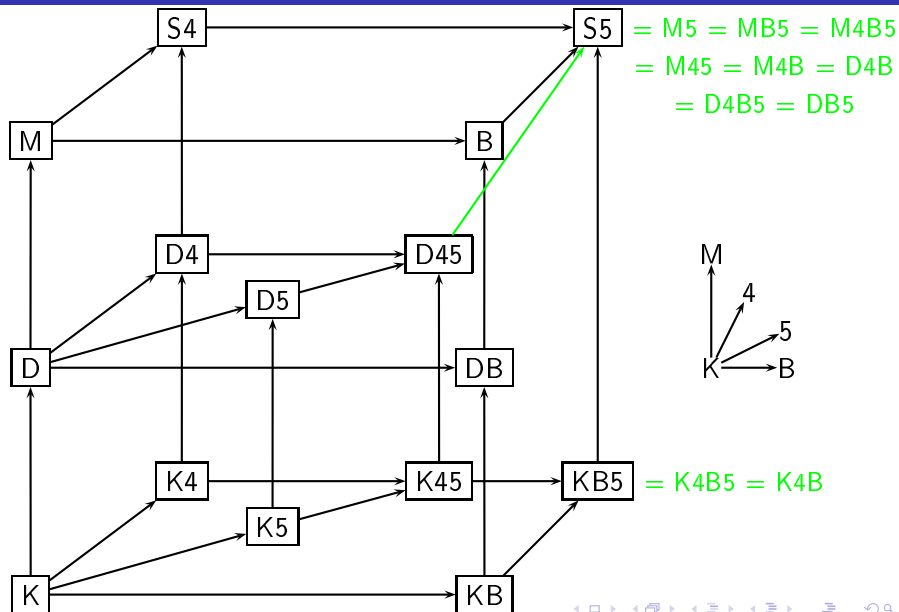

$$\boxed{D} \longrightarrow \boxed{M}$$

Inclusion statement – countermodel by HOL model finder?

$$\forall R. \text{serial}R \Rightarrow (\text{serial}R \wedge \text{reflexive}R)$$

Negated inclusion statement – proof by HOL ATP?

(world1 \neq world2)

$$\neg \forall R. \text{serial}R \Rightarrow (\text{serial}R \wedge \text{reflexive}R)$$

$$\boxed{D} \longrightarrow \boxed{M}$$

Inclusion statement – countermodel by HOL model finder?

$$\forall R. \text{serial } R \Rightarrow (\text{serial } R \wedge \text{reflexive } R)$$

Negated inclusion statement – proof by HOL ATP?

(world1 \neq world2)

⊢

$$\neg \forall R. \text{serial } R \Rightarrow (\text{serial } R \wedge \text{reflexive } R)$$

$$\boxed{D} \longrightarrow \boxed{M}$$

Inclusion statement – countermodel by HOL model finder?

$$\forall R. \text{serial } R \Rightarrow (\text{serial } R \wedge \text{reflexive } R)$$

Negated inclusion statement – proof by HOL ATP?

$$(\text{world1} \neq \text{world2})$$

⊢

$$\neg \forall R. \text{serial } R \Rightarrow (\text{serial } R \wedge \text{reflexive } R)$$

Reasoning about Combinations of Logics: Cube Verification

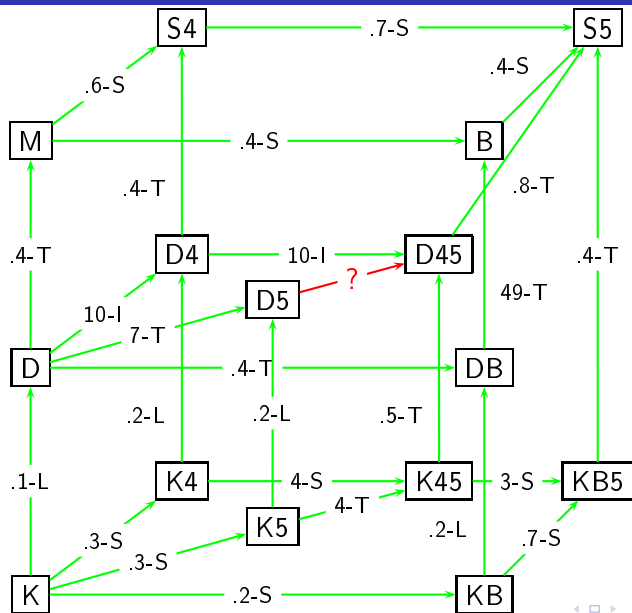

best proving time
(seconds-System)

L=LEO-II
l=IsabelleN
S=Satallax
T=TPS

$\Sigma = 95.1\text{sec}$

Reasoning about Combinations of Logics: Cube Verification

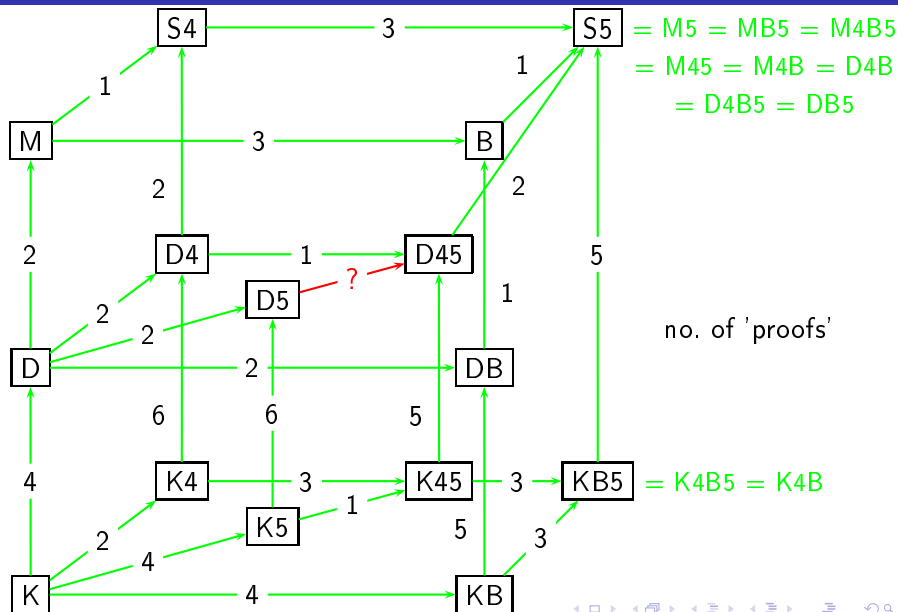

Reasoning about Combinations of Logics: Segerberg

(Segerberg, 1973) discusses a 2-dimensional logic providing two S5 modalities \Box_a and \Box_b . He adds further axioms stating that these modalities are commutative and orthogonal. It actually turns out that orthogonality is already implied in this context.

reflexive a , transitive a , euclid. a ,

reflexive b , transitive b , euclid. b ,

valid $\forall \phi. \Box_a \Box_b \phi \Leftrightarrow \Box_b \Box_a \phi$

\vdash^{HOL}

valid $\forall \phi, \psi. \Box_a (\Box_a \phi \vee \Box_b \psi) \supset (\Box_a \phi \vee \Box_a \psi)$

\wedge

valid $\forall \phi, \psi. \Box_b (\Box_a \phi \vee \Box_b \psi) \supset (\Box_b \phi \vee \Box_b \psi)$

Reasoning about Combinations of Logics: Segerberg

(Segerberg, 1973) discusses a 2-dimensional logic providing two S5 modalities \Box_a and \Box_b . He adds further axioms stating that these modalities are commutative and orthogonal. It actually turns out that orthogonality is already implied in this context.

reflexive a , transitive a , euclid. a ,

reflexive b , transitive b , euclid. b ,

valid $\forall \phi. \Box_a \Box_b \phi \Leftrightarrow \Box_b \Box_a \phi$

\vdash^{HOL}

proof by LEO-II in 0.2s

valid $\forall \phi, \psi. \Box_a (\Box_a \phi \vee \Box_b \psi) \supset (\Box_a \phi \vee \Box_a \psi)$

\wedge

valid $\forall \phi, \psi. \Box_b (\Box_a \phi \vee \Box_b \psi) \supset (\Box_b \phi \vee \Box_b \psi)$



Reasoning within Combined Logics

Wise Men Puzzle

Once upon a time, a king wanted to find the wisest out of his three wisest men. He arranged them in a circle and told them that he would put a white or a black spot on their forehead and that one of the three spots would certainly be white. The three wise men could see and hear each other but, of course, they could not see their faces reflected anywhere. The king, then, asked to each of them to find out the color of his own spot. After a while, the wisest correctly answered that his spot was white.

Wise Men Puzzle

(adapted from (Baltoni, PhD, 1998))

Once upon a time, a king wanted to find the wisest out of his three wisest men. He arranged them in a circle and told them that he would put a white or a black spot on their forehead and that one of the three spots would certainly be white. The three wise men could see and hear each other but, of course, they could not see their faces reflected anywhere. The king, then, asked to each of them to find out the color of his own spot. After a while, the wisest correctly answered that his spot was white.

- ▶ epistemic modalities:

$\square_a, \square_b, \square_c$: three wise men

\square_{fool} : common knowledge

- ▶ predicate constant:

ws : 'has white spot'

Wise Men Puzzle

Once upon a time, a king wanted to find the wisest out of his three wisest men. He arranged them in a circle and told them that he would put a white or a black spot on their forehead and that one of the three spots would certainly be white. The three wise men could see and hear each other but, of course, they could not see their face reflected anywhere. The king, then, asked to each of them to find out the color of his own spot. After a while, the wisest correctly answered that his spot was white.

(adapted from (Baltoni, PhD, 1998))

- ▶ common knowledge:
at least one of the wise men has a white spot

$$\text{valid } \Box_{\text{fool}} (ws\ a) \vee (ws\ b) \vee (ws\ c)$$

if X one has a white spot then Y can see this

$$(\text{valid } \Box_{\text{fool}} (ws\ X) \Rightarrow \Box_Y (ws\ X))$$

if X has not a white spot then Y can see this

$$\text{valid } \Box_{\text{fool}} \neg (ws\ X) \Rightarrow \Box_Y \neg (ws\ X))$$

$$X \neq Y \in \{a, b, c\}$$

Wise Men Puzzle

Once upon a time, a king wanted to find the wisest out of his three wisest men. He arranged them in a circle and told them that he would put a white or a black spot on their forehead and that one of the three spots would certainly be white. The three wise men could see and hear each other but, of course, they could not see their faces reflected anywhere. The king, then, asked to each of them to find out the color of his own spot. After a while, the wisest correctly answered that his spot was white.

(adapted from (Baltoni, PhD, 1998))

- ▶ if X knows ϕ then Y knows this

$$\text{valid } \forall^P \phi. (\Box_X \phi \Rightarrow \Box_Y \Box_X \phi)$$

- ▶ if X does not know ϕ then Y knows this

$$\text{valid } \forall^P \phi. (\neg \Box_X \phi \Rightarrow \Box_Y \neg \Box_X \phi)$$

$$X \neq Y \in \{a, b, c\}$$

- ▶ axioms for common knowledge

$$\text{valid } \forall^P \phi. \Box_{\text{fool}} \phi \Rightarrow \phi \quad (\text{M})$$

$$\text{valid } \forall^P \phi. \Box_{\text{fool}} \phi \Rightarrow \Box_{\text{fool}} \Box_{\text{fool}} \phi \quad (4)$$

$$\forall R. \text{valid } \forall^P \phi. \Box_{\text{fool}} \phi \Rightarrow \Box_R \phi$$

Wise Men Puzzle

(adapted from (Baltoni, PhD, 1998))

Once upon a time, a king wanted to find the wisest out of his three wisest men. He arranged them in a circle and told them that he would put a white or a black spot on their forehead and that one of the three spots would certainly be white. The three wise men could see and hear each other but, of course, they could not see their faces reflected anywhere. The king, then, asked to each of them to find out the color of his own spot. After a while, the wisest correctly answered that his spot was white.

- ▶ a, b do not know that they have a white spot

$$\text{valid} \rightarrow \Box_a (\text{ws } a) \qquad \text{valid} \rightarrow \Box_b (\text{ws } b)$$

- ▶ prove that c does know he has a white spot:

$$\dots \vdash^{HOL} \text{valid} \Box_c (\text{ws } c)$$

Wise Men Puzzle

(adapted from (Baltoni, PhD, 1998))

Once upon a time, a king wanted to find the wisest out of his three wisest men. He arranged them in a circle and told them that he would put a white or a black spot on their forehead and that one of the three spots would certainly be white. The three wise men could see and hear each other but, of course, they could not see their faces reflected anywhere. The king, then, asked to each of them to find out the color of his own spot. After a while, the wisest correctly answered that his spot was white.

- ▶ a, b do not know that they have a white spot

$$\text{valid} \rightarrow \Box_a (ws\ a) \qquad \text{valid} \rightarrow \Box_b (ws\ b)$$

- ▶ prove that c does know he has a white spot:

$$\dots \vdash^{HOL} \text{valid} \Box_c (ws\ c)$$

LEO-II can prove this result in 0.4s

Region Connection Calculus (RCC)

(RandellCuiCohn, 1992)

as fragment of HOL:

disconnected : $dc = \lambda X_{\tau}. \lambda Y_{\tau}. \neg(c X Y)$ part of : $p = \lambda X_{\tau}. \lambda Y_{\tau}. \forall Z. ((c Z X) \Rightarrow (c Z Y))$ identical with : $eq = \lambda X_{\tau}. \lambda Y_{\tau}. ((p X Y) \wedge (p Y X))$ overlaps : $o = \lambda X_{\tau}. \lambda Y_{\tau}. \exists Z. ((p Z X) \wedge (p Z Y))$ partially o : $po = \lambda X_{\tau}. \lambda Y_{\tau}. ((o X Y) \wedge \neg(p X Y) \wedge \neg(p Y X))$ ext. connected : $ec = \lambda X_{\tau}. \lambda Y_{\tau}. ((c X Y) \wedge \neg(o X Y))$ proper part : $pp = \lambda X_{\tau}. \lambda Y_{\tau}. ((p X Y) \wedge \neg(p Y X))$ tangential pp : $tpp = \lambda X_{\tau}. \lambda Y_{\tau}. ((pp X Y) \wedge \exists Z. ((ec Z X) \wedge (ec Z Y)))$ nontang. pp : $ntpp = \lambda X_{\tau}. \lambda Y_{\tau}. ((pp X Y) \wedge \neg \exists Z. ((ec Z X) \wedge (ec Z Y)))$

A trivial problem for RCC:

Catalunya is a border region of Spain (*tpp catalunya spain*),
Spain and France share a border (*ec spain france*),
Paris is a region inside France (*ntpp paris france*)

\vdash^{HOL}

Catalunya and Paris are disconnected (*dc catalunya paris*)

\wedge

Spain and Paris are disconnected (*dc spain paris*)

A trivial problem for RCC:

Catalunya is a border region of Spain (*tpp catalunya spain*),
Spain and France share a border (*ec spain france*),
Paris is a region inside France (*ntpp paris france*)

$\vdash_{2.3s}^{\text{HOL}}$

Catalunya and Paris are disconnected (*dc catalunya paris*)
 \wedge
Spain and Paris are disconnected (*dc spain paris*)

Reasoning within Combined Logics: Epistemic & Spatial

valid $\forall \phi. \Box_{\text{fool}} \phi \supset \Box_{\text{bob}} \phi,$
valid $\Box_{\text{fool}} (\lambda W. (ec \text{ spain france})),$
valid $\Box_{\text{bob}} (\lambda W. (tpp \text{ catalunya spain})),$
valid $\Box_{\text{bob}} (\lambda W. (ntpp \text{ paris france}))$
 \vdash^{HOL} valid $\Box_{\text{bob}} (\lambda W. ((dc \text{ catalunya paris}) \wedge (dc \text{ spain paris})))$

valid $\forall \phi. \Box_{\text{fool}} \phi \supset \Box_{\text{bob}} \phi,$
valid $\Box_{\text{fool}} (\lambda W. (ec \text{ spain france})),$
valid $\Box_{\text{bob}} (\lambda W. (tpp \text{ catalunya spain})),$
valid $\Box_{\text{bob}} (\lambda W. (ntpp \text{ paris france}))$
 $\vdash_{20.4s}^{HOL}$ valid $\Box_{\text{bob}} (\lambda W. ((dc \text{ catalunya paris}) \wedge (dc \text{ spain paris})))$

valid $\forall \phi. \Box_{\text{fool}} \phi \supset \Box_{\text{bob}} \phi,$
valid $\Box_{\text{fool}} (\lambda W. (ec \text{ spain france})),$
valid $\Box_{\text{bob}} (\lambda W. (tpp \text{ catalunya spain})),$
valid $\Box_{\text{bob}} (\lambda W. (ntpp \text{ paris france}))$
 $\vdash_{20.4s}^{HOL}$ valid $\Box_{\text{bob}} (\lambda W. ((dc \text{ catalunya paris}) \wedge (dc \text{ spain paris})))$
 $\not\vdash^{HOL}$ valid $\Box_{\text{fool}} (\lambda W. ((dc \text{ catalunya paris}) \wedge (dc \text{ spain paris})))$

valid $\forall \phi. \Box_{\text{fool}} \phi \supset \Box_{\text{bob}} \phi,$

valid $\Box_{\text{fool}} (\lambda W. (ec \text{ spain france})),$

valid $\Box_{\text{bob}} (\lambda W. (tpp \text{ catalunya spain})),$

valid $\Box_{\text{bob}} (\lambda W. (ntpp \text{ paris france}))$

$\vdash_{20.4s}^{HOL}$ valid $\Box_{\text{bob}} (\lambda W. ((dc \text{ catalunya paris}) \wedge (dc \text{ spain paris})))$

$\not\vdash_{39.7s}^{HOL}$ valid $\Box_{\text{fool}} (\lambda W. ((dc \text{ catalunya paris}) \wedge (dc \text{ spain paris})))$

Reasoning within Combined Logics: Epistemic & Spatial

$\text{valid } \forall \phi. \Box_{\text{fool}} \phi \supset \Box_{\text{bob}} \phi,$
 $\text{valid } \Box_{\text{fool}} (\lambda W. (ec \text{ spain } france)),$
 $\text{valid } \Box_{\text{bob}} (\lambda W. (tpp \text{ catalunya } spain)),$
 $\text{valid } \Box_{\text{bob}} (\lambda W. (ntpp \text{ paris } france))$
 $\vdash_{20.4s}^{HOL} \text{valid } \Box_{\text{bob}} (\lambda W. ((dc \text{ catalunya } paris) \wedge (dc \text{ spain } paris)))$
 $\not\vdash_{39.7s}^{HOL} \text{valid } \Box_{\text{fool}} (\lambda W. ((dc \text{ catalunya } paris) \wedge (dc \text{ spain } paris)))$

Key idea is “Lifting” of RCC propositions to modal predicates:

$\underbrace{(tpp \text{ catalunya } spain)}_{\text{type } o} \longrightarrow \underbrace{(\lambda W. (tpp \text{ catalunya } spain))}_{\text{type } \iota \rightarrow o}$



LEO-II

(EPSRC grant EP/D070511/1 at Cambridge University)

Thanks to Larry Paulson

LEO-II

UNIVERSITY OF CAMBRIDGE
UNIVERSITÄT DES SAARLANDES

An Effective Higher-Order Theorem Prover

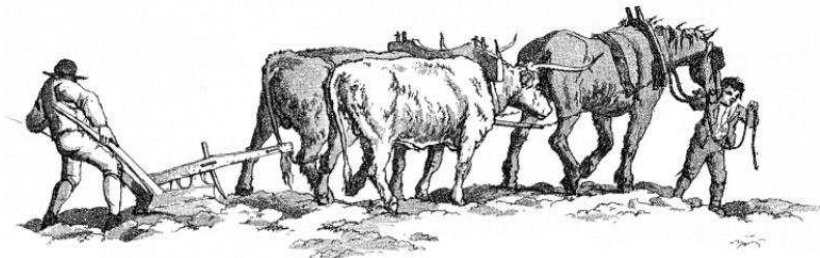

LEO-II employs FO-ATPs: E, Spass, Vampire

<http://www.ags.uni-sb.de/~leo>

Summary I

- ▶ HOL seems well suited as framework for combining logics
- ▶ automation of object-/meta-level reasoning — scalability?
- ▶ embeddings can possibly be fully verified in Isabelle/HOL?
(consistency of QML embedding: 3.8s – IsabelleN)
- ▶ current work: application to ontology reasoning (SUMO)

You can use this framework right away! Try it!

- ▶ new TPTP infrastructure for automated HOL reasoning
(SutcliffeBenzmüller, J. Formalized Reasoning, 2010)
 - ▶ standardized input / output language (THF)
 - ▶ problem library: 3000 problems
 - ▶ yearly CASC competitions
- ▶ provers and examples are online; demo: <http://tptp.org>
Wise Men Puzzle:

<http://www.cs.miami.edu/~tptp/cgi-bin/SeeTPTP?Category=Problems&Domain=PUZ&File=PUZ087~1.p>



ONTOLEO (DFG grant BE 2501/6-1)
Application in Higher-Order Ontology Reasoning
(jww Adam Pease)

Background: SUMO and Sigma

- ▶ SUMO — Suggested Upper-Level Ontology (NilesPease, FOIS, 2001)
 - ▶ open source, formal ontology: www.ontologyportal.org
 - ▶ has been extended for a number of domain specific ontologies
 - ▶ altogether approx. 20,000 terms and 70,000 axioms
 - ▶ employs the SUO-KIF representation language, a simplification of Genesereth's original Knowledge Interchange Format (KIF)
- ▶ Sigma: browsing and inference system for ontology development (Pease, CEUR-71, 2003)

Important: SUMO (and similarly Cyc) contains a small but significant amount of **higher-order representations** (e.g. embedded formulas and modalities), but there is only very limited automation support so far

⇒ better automation support is goal of the ONTOLOEO project

Background: SUMO and Sigma

- ▶ SUMO — Suggested Upper-Level Ontology (NilesPease, FOIS, 2001)
 - ▶ open source, formal ontology: www.ontologyportal.org
 - ▶ has been extended for a number of domain specific ontologies
 - ▶ altogether approx. 20,000 terms and 70,000 axioms
 - ▶ employs the SUO-KIF representation language, a simplification of Genesereth's original Knowledge Interchange Format (KIF)
- ▶ Sigma: browsing and inference system for ontology development (Pease, CEUR-71, 2003)

Important: SUMO (and similarly Cyc) contains a small but significant amount of **higher-order representations** (e.g. embedded formulas and modalities), but there is only very limited automation support so far

⇒ **better automation support is goal of the ONTOLOEO project**

- ▶ achieved:

SUO-KIF \longrightarrow THF

translation mechanism for SUMO as part of Sigma

- ▶ main challenge: find consistent typing for 'untyped' SUO-KIF

`(instance instance BinaryPredicate)`

- ▶ translation example available at:

<http://www.ags.uni-sb.de/~chris/papers/SUMO.thf>

Example (I: Reasoning in temporal contexts)

What holds that holds at all times. Mary likes Bill. During 2009 Sue liked whoever Mary liked. Is there a year in which Sue has liked somebody?

A: `(=> ?P (holdsDuring ?Y ?P))`

B: `(likes Mary Bill)`

C: `(holdsDuring (YearFn 2009)
 (forall (?X) (=> (likes Mary ?X) (likes Sue ?X))))`

Query: `(holdsDuring (YearFn ?Y) (likes Sue ?X))`

Proof by LEO-II in 0.16s

Example (I: Reasoning in temporal contexts)

What holds that holds at all times. Mary likes Bill. During 2009 Sue liked whoever Mary liked. Is there a year in which Sue has liked somebody?

A: (\Rightarrow ?P (holdsDuring ?Y ?P))

B: (likes Mary Bill)

C: (holdsDuring (YearFn 2009)
(forall (?X) (\Rightarrow (likes Mary ?X) (likes Sue ?X))))

Query: (holdsDuring (YearFn ?Y) (likes Sue ?X))

Proof by LEO-II in 0.16s

Example (II: Reasoning in temporal contexts – I modified)

What holds that holds at all times. Mary likes Bill. During 2009 Sue liked whoever Mary liked. Is there a year in which Sue has liked somebody?

A: `(=> ?P (holdsDuring ?Y ?P))`

B: `(likes Mary Bill)`

C: `(holdsDuring (YearFn 2009)
 (forall (?X) (=> (likes Mary ?X) (likes Sue ?X))))`

Query: `(holdsDuring (YearFn ?Y) (likes Sue ?X))`

Example (II: Reasoning in temporal contexts – I modified)

What holds that holds at all times. Mary likes Bill. During 2009 Sue liked whoever Mary liked. Is there a year in which Sue has liked somebody?

A': `(holdsDuring ?Y True)`

B: `(likes Mary Bill)`

C: `(holdsDuring (YearFn 2009)
 (forall (?X) (=> (likes Mary ?X) (likes Sue ?X))))`

Query: `(holdsDuring (YearFn ?Y) (likes Sue ?X))`

Example (II: Reasoning in temporal contexts – I modified)

What holds that holds at all times. Mary likes Bill. During 2009 Sue liked whoever Mary liked. Is there a year in which Sue has liked somebody?

A': `(holdsDuring ?Y (1 + 1 = 2))`

B: `(likes Mary Bill)`

C: `(holdsDuring (YearFn 2009)
 (forall (?X) (=> (likes Mary ?X) (likes Sue ?X))))`

Query: `(holdsDuring (YearFn ?Y) (likes Sue ?X))`

Example (II: Reasoning in temporal contexts – I modified)

What holds that holds at all times. Mary likes Bill. During 2009 Sue liked whoever Mary liked. Is there a year in which Sue has liked somebody?

A': `(holdsDuring ?Y (forall (?P) (=> ?P ?P)))`

B: `(likes Mary Bill)`

C: `(holdsDuring (YearFn 2009)
 (forall (?X) (=> (likes Mary ?X) (likes Sue ?X))))`

Query: `(holdsDuring (YearFn ?Y) (likes Sue ?X))`

Example (II: Reasoning in temporal contexts – I modified)

What holds that holds at all times. Mary likes Bill. During 2009 Sue liked whoever Mary liked. Is there a year in which Sue has liked somebody?

A': `(holdsDuring ?Y True)`

B: `(likes Mary Bill)`

C: `(holdsDuring (YearFn 2009)
 (forall (?X) (=> (likes Mary ?X) (likes Sue ?X))))`

Query: `(holdsDuring (YearFn ?Y) (likes Sue ?X))`

Boolean extensionality: $(P \Leftrightarrow Q) \Leftrightarrow (P = Q)$

Example (II: Reasoning in temporal contexts – I modified)

What holds that holds at all times. Mary likes Bill. During 2009 Sue liked whoever Mary liked. Is there a year in which Sue has liked somebody?

A': `(holdsDuring ?Y True)`

B: `(likes Mary Bill)`

C: `(holdsDuring (YearFn 2009)
 (forall (?X) (=> (likes Mary ?X) (likes Sue ?X))))`

Query: `(holdsDuring (YearFn ?Y) (likes Sue ?X))`

Proof by LEO-II in 0.08s

Example (III: Reasoning in epistemic contexts – II modified)

A'': (knows ?Y True)

B: (likes Mary Bill)

C': (knows Chris

(forall (?X) (=> (likes Mary ?X) (likes Sue ?X))))

Query': (knows Chris (likes Sue Bill))

Proof by LEO-II in 0.04s

Boolean extensionality is in conflict with (epistemic) modalities!

(Has Boolean extensionality ever been questioned for KIF?)

Example (III: Reasoning in epistemic contexts – II modified)

A'': (knows ?Y (1 + 1 = 2))

B: (likes Mary Bill)

C': (knows Chris

(forall (?X) (=> (likes Mary ?X) (likes Sue ?X))))

Query': (knows Chris (likes Sue Bill))

Proof by LEO-II in 0.04s

Boolean extensionality is in conflict with (epistemic) modalities!

(Has Boolean extensionality ever been questioned for KIF?)

Example (III: Reasoning in epistemic contexts – II modified)

A'': (knows ?Y True)

B: (likes Mary Bill)

C': (knows Chris

(forall (?X) (=> (likes Mary ?X) (likes Sue ?X))))

Query': (knows Chris (likes Sue Bill))

Proof by LEO-II in 0.04s

Boolean extensionality is in conflict with (epistemic) modalities!

(Has Boolean extensionality ever been questioned for KIF?)

Example (III: Reasoning in epistemic contexts – II modified)

A'': (knows ?Y True)

B: (likes Mary Bill)

C': (knows Chris

(forall (?X) (=> (likes Mary ?X) (likes Sue ?X))))

Query': (knows Chris (likes Sue Bill))

Proof by LEO-II in 0.04s

Boolean extensionality is in conflict with (epistemic) modalities!

(Has Boolean extensionality ever been questioned for KIF?)

Solution: Translate into Quantified Multimodal Logic QML

- ▶ T-Box like information in SUMO:

(instance holdsDuring AsymmetricRelation) \longrightarrow
valid (instance holdsDuring AsymmetricRelation) $_{l \rightarrow o}$

- ▶ A-Box like information as in query problem: current world cw_l

(likes Mary Bill) \longrightarrow
(likes Mary Bill) $_{l \rightarrow o} cw_l$

(knows Chris (likes Sue Bill)) \longrightarrow
(\square_{Chris} (likes Sue Bill)) $_{l \rightarrow o} cw_l$

Solution: Translate into Quantified Multimodal Logic QML

- ▶ T-Box like information in SUMO:

(instance holdsDuring AsymmetricRelation) \longrightarrow
 $\forall W_t. (\text{instance holdsDuring AsymmetricRelation})_{t \rightarrow o} W_t$

- ▶ A-Box like information as in query problem: current world cw_t

(likes Mary Bill) \longrightarrow
 $(\text{likes Mary Bill})_{t \rightarrow o} cw_t$

(knows Chris (likes Sue Bill)) \longrightarrow
 $(\Box_{\text{Chris}} (\text{likes Sue Bill}))_{t \rightarrow o} cw_t$

Solution: Translate into Quantified Multimodal Logic QML

- ▶ T-Box like information in SUMO:

(instance holdsDuring AsymmetricRelation) \longrightarrow
 $\forall W_\iota. (\text{instance holdsDuring AsymmetricRelation})_{\iota \rightarrow o} W_\iota$

- ▶ A-Box like information as in query problem: current world cw_ι

(likes Mary Bill) \longrightarrow
 $(\text{likes Mary Bill})_{\iota \rightarrow o} cw_\iota$

(knows Chris (likes Sue Bill)) \longrightarrow
 $(\Box_{\text{Chris}} (\text{likes Sue Bill}))_{\iota \rightarrow o} cw_\iota$

Example (III: Reasoning in epistemic contexts – Solution)

A'': $\forall Y_{l \rightarrow l \rightarrow o} (\Box_Y \top)_{cw}$

B: $(\text{likes Mary Bill})_{cw}$

C': $(\Box_{Chris} (\forall^i X_{\mu} ((\text{likes Mary } X) \supset (\text{likes Sue } X))))_{cw}$

Query': $(\Box_{Chris} (\text{likes Sue Bill}))_{cw}$

Axioms for \Box_{Chris} can be added:

M: $\text{valid } \forall^P \phi_{l \rightarrow o} \Box_{Chris} \phi \supset \phi$

4: $\text{valid } \forall^P \phi_{l \rightarrow o} \Box_{Chris} \phi \supset \Box_{Chris} \Box_{Chris} \phi$

5: $\text{valid } \forall^P \phi_{l \rightarrow o} \Diamond_{Chris} \phi \supset \Box_{Chris} \Diamond_{Chris} \phi$

Example (III: Reasoning in epistemic contexts – Solution)

A'': $\forall Y_{\iota \rightarrow \iota \rightarrow o} (\Box_Y \top)_{CW}$

B: $(\text{likes Mary Bill})_{CW}$

C': $(\Box_{Chris} (\forall^i X_{\mu} ((\text{likes Mary } X) \supset (\text{likes Sue } X))))_{CW}$

Query': $(\Box_{Chris} (\text{likes Sue Bill}))_{CW}$

Axioms for \Box_{Chris} can be added:

M: $\text{valid } \forall^P \phi_{\iota \rightarrow o} \Box_{Chris} \phi \supset \phi$

4: $\text{valid } \forall^P \phi_{\iota \rightarrow o} \Box_{Chris} \phi \supset \Box_{Chris} \Box_{Chris} \phi$

5: $\text{valid } \forall^P \phi_{\iota \rightarrow o} \Diamond_{Chris} \phi \supset \Box_{Chris} \Diamond_{Chris} \phi$

Example (III: Reasoning in epistemic contexts – Solution)

A'': $\forall Y_{l \rightarrow l \rightarrow o} (\Box_Y \top)_{CW}$

B: $(\text{likes Mary Bill})_{CW}$

C': $(\Box_{Chris} (\forall^i X_{\mu} ((\text{likes Mary } X) \supset (\text{likes Sue } X))))_{CW}$

Query': $(\Box_{Chris} (\text{likes Sue Bill}))_{CW}$

Axioms for \Box_{Chris} can be added:

M: $\text{valid } \forall^P \phi_{l \rightarrow o} \Box_{Chris} \phi \supset \phi$

4: $\text{valid } \forall^P \phi_{l \rightarrow o} \Box_{Chris} \phi \supset \Box_{Chris} \Box_{Chris} \phi$

5: $\text{valid } \forall^P \phi_{l \rightarrow o} \Diamond_{Chris} \phi \supset \Box_{Chris} \Diamond_{Chris} \phi$

LEO-II cannot solve this problem anymore!

Example (III: Reasoning in epistemic contexts – Solution)

A'': $\forall Y_{\ell \rightarrow \ell \rightarrow o} (\Box_Y \top) \text{ cw}$

B: $(\Box_{Chris} (\text{likes Mary Bill})) \text{ cw}$

C': $(\Box_{Chris} (\forall^i X_{\mu} ((\text{likes Mary } X) \supset (\text{likes Sue } X)))) \text{ cw}$

Query': $(\Box_{Chris} (\text{likes Sue Bill})) \text{ cw}$

Axioms for \Box_{Chris} can be added:

M: **valid** $\forall^P \phi_{\ell \rightarrow o} \Box_{Chris} \phi \supset \phi$

4: **valid** $\forall^P \phi_{\ell \rightarrow o} \Box_{Chris} \phi \supset \Box_{Chris} \Box_{Chris} \phi$

5: **valid** $\forall^P \phi_{\ell \rightarrow o} \Diamond_{Chris} \phi \supset \Box_{Chris} \Diamond_{Chris} \phi$

But LEO-II can solve this problem (0.15s) !

Example (III: Reasoning in epistemic contexts – Solution)

A'' : $\forall Y_{l \rightarrow l \rightarrow o} (\Box_Y \top)_{CW}$

B : $(\Box_{fool} (\text{likes Mary Bill}))_{CW}$

C' : $(\Box_{Chris} (\forall^i X_{\mu} ((\text{likes Mary } X) \supset (\text{likes Sue } X))))_{CW}$

Query': $(\Box_{Chris} (\text{likes Sue Bill}))_{CW}$

Axioms for \Box_{Chris} can be added:

M : $\text{valid } \forall^P \phi_{l \rightarrow o} \Box_{Chris} \phi \supset \phi$

4: $\text{valid } \forall^P \phi_{l \rightarrow o} \Box_{Chris} \phi \supset \Box_{Chris} \Box_{Chris} \phi$

5: $\text{valid } \forall^P \phi_{l \rightarrow o} \Diamond_{Chris} \phi \supset \Box_{Chris} \Diamond_{Chris} \phi$

Axioms for \Box_{fool} can be added ...

Summary II

- ▶ SUMO (and similarly Cyc) employ higher-order representations: embedded formulas, modalities, relation variables, lambda-abstraction, etc.
- ▶ automation remains a challenge
- ▶ progress possible with HOL/THF provers
- ▶ problem detected: Boolean extensionality versus modalities
- ▶ solution proposed: employ our embedding of Quantified Multimodal Logic into HOL/THF
- ▶ further reading: (BenzmüllerPease, ARCOE-10, 2010)
(BenzmüllerPease, PAAR, 2010)

- ▶ Is there any other system/approach that can elegantly encode and solve all the problems presented here? Please let me know!

Summary I

- ▶ HOL seems well suited as framework for combining logics
- ▶ automation of object-/meta-level reasoning — scalability?
- ▶ embeddings can possibly be fully verified in Isabelle/HOL?
(consistency of QML embedding: 3.8s – IsabelleN)
- ▶ current work: application to ontology reasoning (SUMO)

You can use this framework right away! Try it!

- ▶ new TPTP infrastructure for automated HOL reasoning
(SutcliffeBenzmüller, J. Formalized Reasoning, 2010)
 - ▶ standardized input / output language (THF)
 - ▶ problem library: 3000 problems
 - ▶ yearly CASC competitions
- ▶ provers and examples are online; demo: <http://tptp.org>
Wise Men Puzzle:

<http://www.cs.miami.edu/~tptp/cgi-bin/SeeTPTP?Category=Problems&Domain=PUZ&File=PUZ087~1.p>

