

System Description:

LEO – A Higher Order Theorem Prover<sup>a</sup>

Christoph Benz Müller and Michael Kohlhase

`chris|kohlhase@cs.uni-sb.de`

The  $\Omega$ MEGA Group

Universität des Saarlandes, Saarbrücken, Germany

July 7, Lindau, Germany

---

<sup>a</sup>This work was supported by the Deutsche Forschungsgemeinschaft in grant HOTEL and by the Studienstiftung des Deutschen Volkes



## THEORETICAL ASPECTS OF LEO

- ▶ Calculus: **Extensional HO Resolution**
- ▶ Built-in Extensionality Principles
- ▶ Extended SOS Architecture:
  - Extensionality Treatment
  - Interleaved HO Unification and Resolution
  - Primitive Substitution
  - Continuation of HO Unification
- ▶ Problems:
  - Leibniz-Equality or Primitive Equality
  - HO Term-Indexing is not compatible with Extensional HO Resolution
  - HO Subsumption



## Architecture of LEO

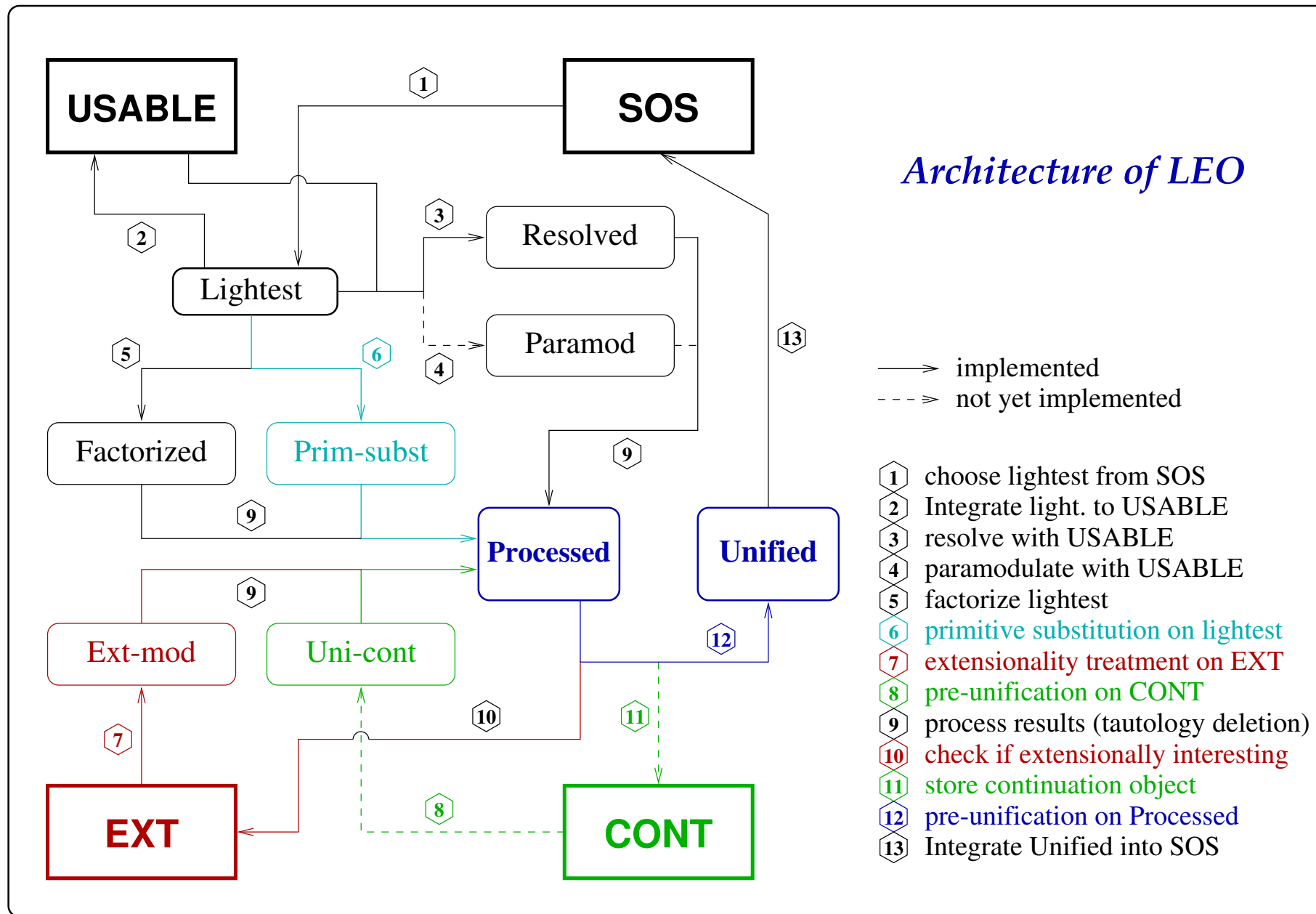

## TECHNICAL ASPECTS OF LEO

- ▶ Implemented in Allegro Common Lisp
- ▶ Tested under Solaris and Linux
- ▶ Datastructures based on the KEIM-Toolbox
- ▶ Version LEO1 is available via

<http://www.ags.uni-sb.de/projects/deduktion/projects/hot/leo/>

- ▶ Features of LEO1:
  - Automatic Mode for Extensional HO Resolution
  - Interactive Mode in a Simple Command Shell
- ▶ New Features of LEO3 (not yet available):
  - Integrated in the  $\Omega$ MEGA-system
  - Graphical Proof Display and User Interface
  - Access to  $\Omega$ MEGA's Knowledge Base and other Reasoning Systems



## Examples about sets

LEO outperforms well known FO Theorem Provers on simple theorems about sets (e.g. Boolean Properties of Sets, Journal of Formalized Mathematics Volume 1, 1989)

### Examples:

28) If  $X \subseteq Y$  and  $Y \subseteq X$  then  $X = Y$

80) If  $(X \cap Y) \cup (X \setminus Y) = X$

99)  $(X \dot{-} Y) \dot{-} Z = X \dot{-} (Y \dot{-} Z)$

See: <http://www-irm.mathematik.hu-berlin.de/~ilf/miz2atp/mizstat.html>

Solved theorems (of 97)	
Waldmeister (pure equality prover, only Th 72 and 99 have been tried)	1
Spass v0.78 (on Ultra Sparc 170)	72
Setheo v3.3 ("on" PVM)	76
CM v10-15-97 (ME Prover in Prolog)	72
CM v10-15-97 (with special cost function [hdef(d1,6,1,6)])	76
CM v9-22-97 (with definition expansion in the theorem)	79
Otter (auto)	60
Gandalf v. c-1.0b	47
Spass v0.54	52
Setheo	53
All Together	94
LEO	95



EXAMPLE:  $p_{oo}a_o \wedge p_{oo}b_o \Rightarrow p_{oo}(a_o \wedge b_o)$

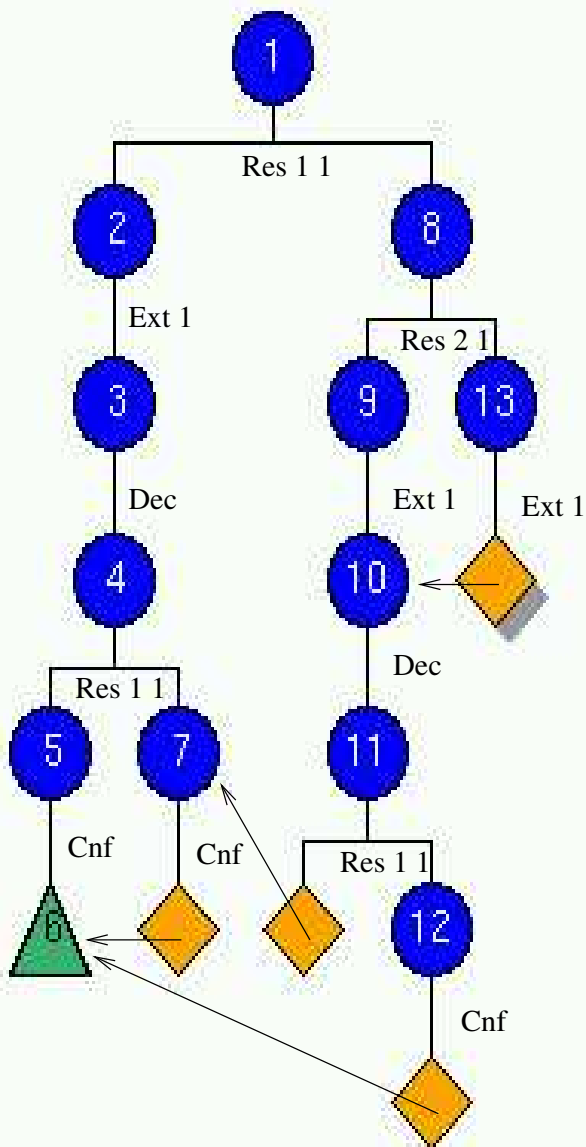

- 1 :  $\perp$
- 2 :  $b$
- 3 :  $\neg(b = (a \wedge b))$
- 4 :  $\neg((pb) = (p(a \wedge b)))$
- 5 :  $pb$
- 6 :  $\neg(((pa) \wedge (pb)) \Rightarrow (p(a \wedge b)))$
- 7 :  $\neg(p(a \wedge b))$
- 8 :  $\neg b$
- 9 :  $\neg a \vee \neg b$
- 10 :  $\neg(a = (a \wedge b))$
- 11 :  $\neg((pa) = (p(a \wedge b)))$
- 12 :  $pa$
- 13 :  $a$



# EXAMPLE: $\wp(\emptyset) = \{\emptyset\}$

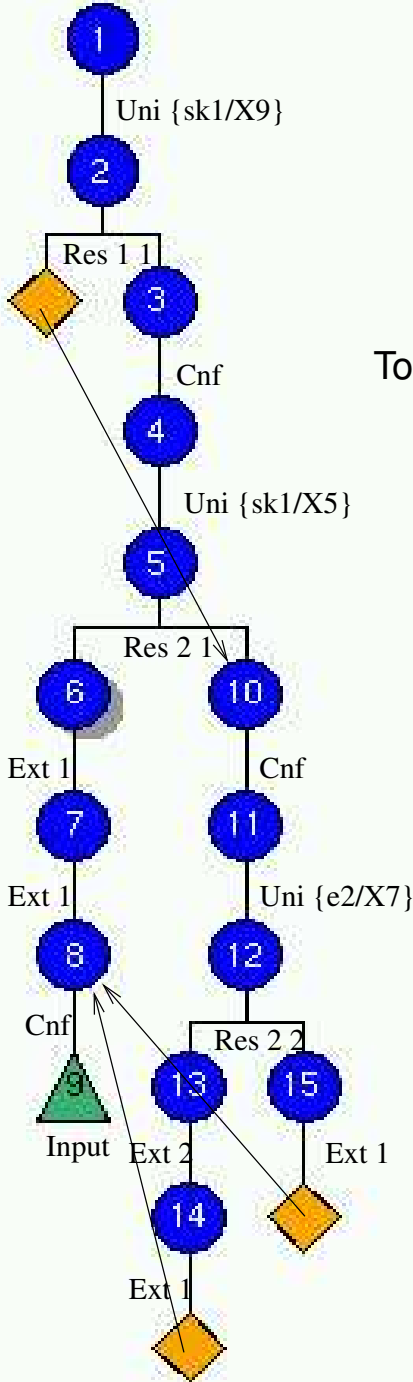

Def.:

$$\wp = \lambda A_{o\alpha}. \lambda B_{o\alpha}. \overbrace{\forall X_{\alpha} B X \Rightarrow A X}^{B \subseteq A}$$

$$\{\} = \lambda X_{\beta}. \lambda Y_{\beta}. Y = X$$

$$\emptyset = \lambda Y_{\gamma}. \perp$$

To show:

$$\neg((\lambda B_{o\alpha}. (\forall X_{\alpha}. (B X) \Rightarrow \perp)) = (\lambda B_{o\alpha}. B = \lambda Y_{\alpha}. \perp))$$

- 1 :  $\perp$
- 2 :  $\neg(e_{o\alpha}^1 X_{\alpha}^9 = e_{o\alpha}^1 sk^1)$
- 3, 4 :  $(e_{o\alpha}^1 X_{\alpha}^8)$
- 5 :  $\neg(e_{o\alpha}^1 X_{\alpha}^5 = e_{o\alpha}^1 sk^1) \vee \neg(e_{o\alpha}^1 X_{\alpha}^6)$
- 6 :  $\neg(e_{o\alpha}^1 X_{\alpha}^2) \vee \neg(e_{o\alpha}^1 X_{\alpha}^3)$
- 7 :  $\neg(e_{o\alpha}^1 X_{\alpha}^1) \vee (e_{o\alpha}^1 = \lambda z. \perp)$
- 8, 9 :  $\neg((\lambda B_{o\alpha}. (\forall X_{\alpha}. (B X) \Rightarrow \perp)) = (\lambda B_{o\alpha}. B = \lambda Y_{\alpha}. \perp))$
- 10, 11 :  $(e_{o\alpha}^1 sk^1)$
- 12 :  $\neg(e_{o\alpha}^1 e^2 = e_{o\alpha}^1 X_{\alpha}^7) \vee (e_{o\alpha}^1 sk^1)$
- 13 :  $(e_{o\alpha}^1 e^2) \vee (e_{o\alpha}^1 sk^1)$
- 14 :  $\neg(e_{o\alpha}^1 = \lambda Y_{\alpha}. \perp) \vee (e_{o\alpha}^1 sk^1)$
- 15 :  $\neg(e_{o\alpha}^1 X_{\alpha}^4) \vee (e_{o\alpha}^1 sk^1)$



## Conclusion

- ▶ LEO implements Extensional Higher Order Resolution
- ▶ Henkin-Completeness without Extensionality Axioms
- ▶ Interleaving of Resolution and Unification
- ▶ Well suited for simple theorems about sets

## Current and future work

- ▶ Integration in  $\Omega$ MEGA
- ▶ Primitive Equality
- ▶ Primitive Substitution
- ▶ More efficient implementation
- ▶ Cooperation with other Reasoning Systems

